

END COVER COLOR : BLACK

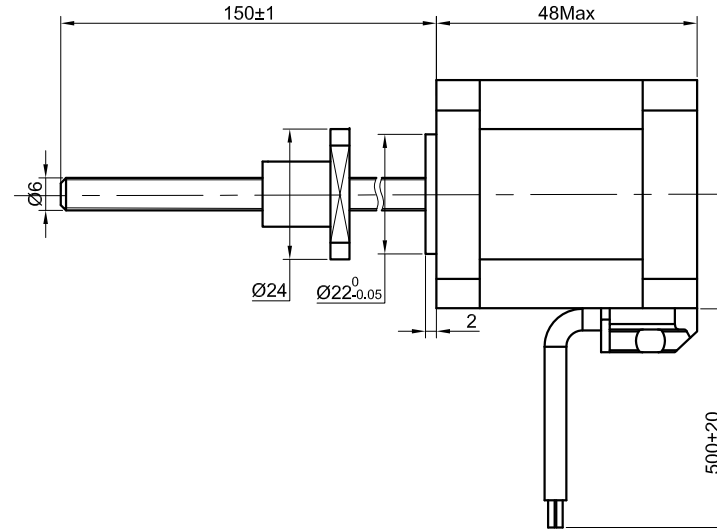
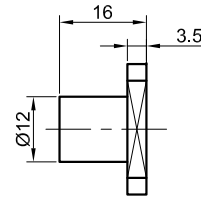
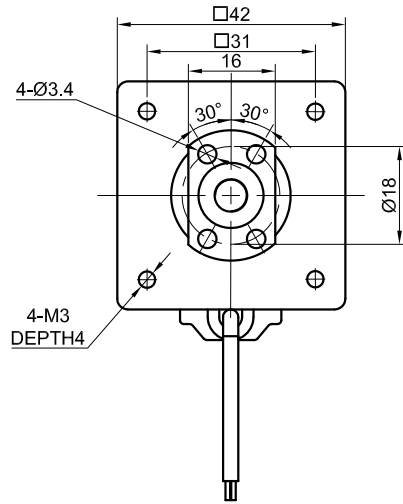

| SPECIFICATION  | CONNECTION | BIPOLAR   |
|--|------------|-----------|
| AMPS/PHASE   |            | 2.5       |
| RESISTANCE/PHASE(Ohms)@25°C  |            | 0.78±10%  |
| INDUCTANCE/PHASE(mH)@1KHz  |            | 1.5±20%   |
| HOLDING TORQUE(Nm)[lb-in]  |            | 0.5[4.43] |
| LEAD(mm)   |            | 2         |
| LINEAR TRAVEL/STEP(mm)   |            | 0.01      |
| STEP ANGLE(°)  |            | 1.80      |
| STEP ACCURACY(NON-ACCUM)   |            | ±5.00%    |
| WEIGHT(Kg)[lb]   |            | —         |
| TEMPERATURE RISE:MAX.80°C ( MOTOR STANDSTILL;FOR 2PHASE ENERGIZED)               |            |           |
| AMBIENT TEMPERATURE -10°C~50°C[14°F~122°F]                                       |            |           |
| INSULATION RESISTANCE 100 Mohm (UNDER NORMAL TEMPERATURE AND HUMIDITY)           |            |           |
| INSULATION CLASS B 130°C[266°F]  |            |           |
| DIELECTRIC STRENGTH 500VAC FOR 1MIN.(BETWEEN THE MOTOR COILS AND THE MOTOR CASE) |            |           |
| AMBIENT HUMIDITY MAX.85%(NO CONDENSATION)  |            |           |

| TYPE OF CONNECTION (EXTERN) |         | MOTOR   |         |
|-----------------------------|---------|---------|---------|
| PIN NO                      | BIPOLAR | LEADS   | WINDING |
| 1                           | A —     | RED     |         |
| 2                           | A\ —    | RED/WHT |         |
| 3                           | B —     | GRN     |         |
| 4                           | B\ —    | GRN/WHT |         |

FULL STEP 2 PHASE-Ex. ,  
WHEN FACING MOUNTING END (X)

| STEP | A | B | A\ | B\ |  | CCW |
|------|---|---|----|----|--|-----|
| 1    | + | + | -  | -  |  |     |
| 2    | - | + | +  | -  |  |     |
| 3    | - | - | +  | +  |  |     |
| 4    | + | - | -  | +  |  |     |

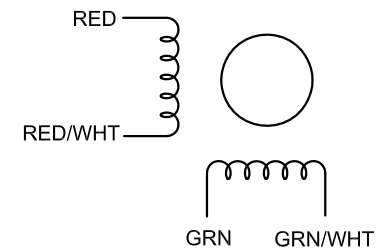

|       |           |  |           |
|-------|-----------|--|-----------|
|       | APVD      |  | 8.29.2022 |
|       | CHKD      |  |           |
| 3:2   | DRN       |  |           |
| SCALE | SIGNATURE |  | DATE      |

# STEPPER MOTOR

17E19S2504BAM5-150RS